

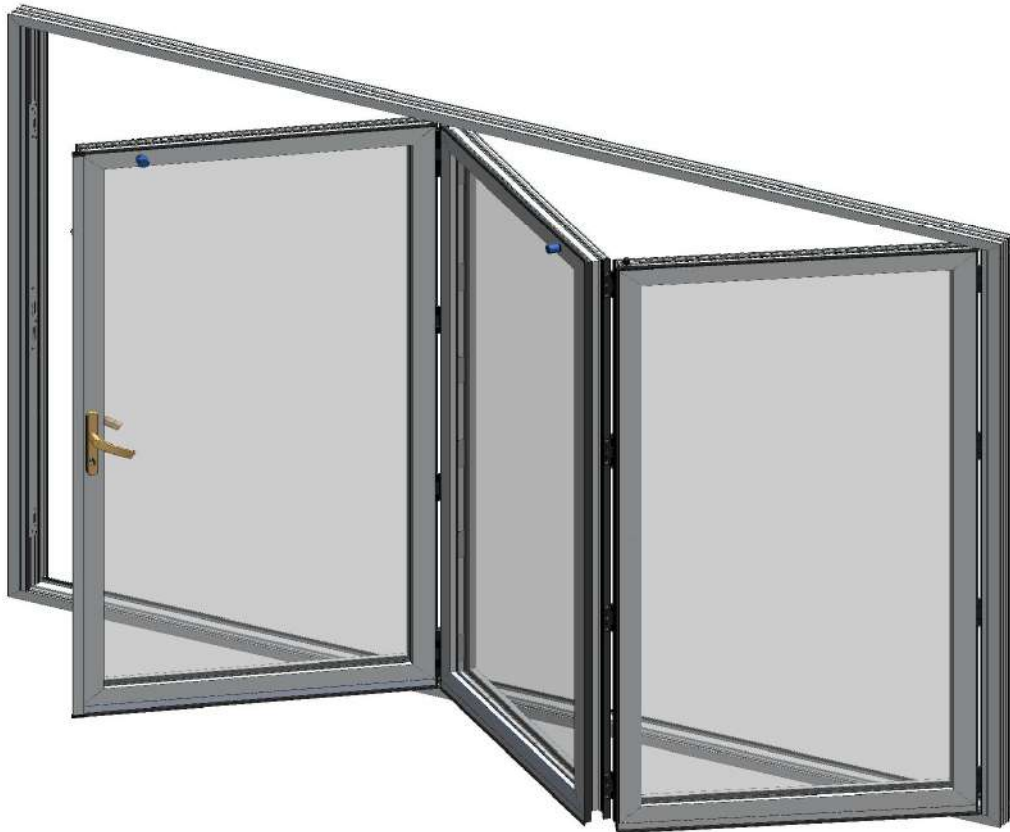

# 達洛維摺疊門 安裝簡介

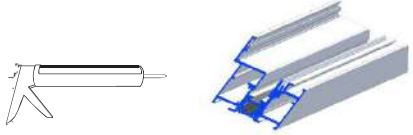
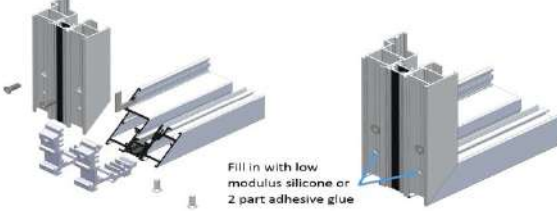

## 外框架組裝

<p>在所有外框架連接片和框架組件之間塗抹結構矽膠</p>	
<p>使用連接片和機器螺釘連接外框角，如圖所示將結構膠打入預留孔中，堅固結合</p>	 <p>Fill in with low modulus silicone or 2 part adhesive glue</p>
<p>對所有四個外框角重複相同的過程</p>	

## 低門檻組裝

<p>使用專用固定套件安裝 在所有框架連接片和框架組件之間塗抹矽膠 確保沒有水可以通過側柱從低門檻滲入</p>	
---	---

## 外框安裝

<p>框架移入結構開口中，確保框架在開口內垂直和直角 如使用焊接固定，需確保框架在開口內垂直和直角 確保頂部和底部框架在整個長度上保持垂直和直角</p>	
--	--

## 可調節側柱安裝

<p>移除附在可調節側柱上的密封條或墊高型材 將可調節側柱型材安裝到外框架中直至末端</p>	 <p>REMOVE THE SEALS</p> <p>FIT ADJUSTABLE JAMB</p>
--	---

## 門扇安裝

按照門扇編號，由與外框固定端依序進行安裝

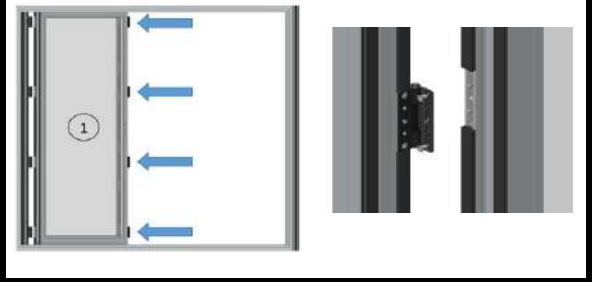

帶導輪絞鏈門扇安裝

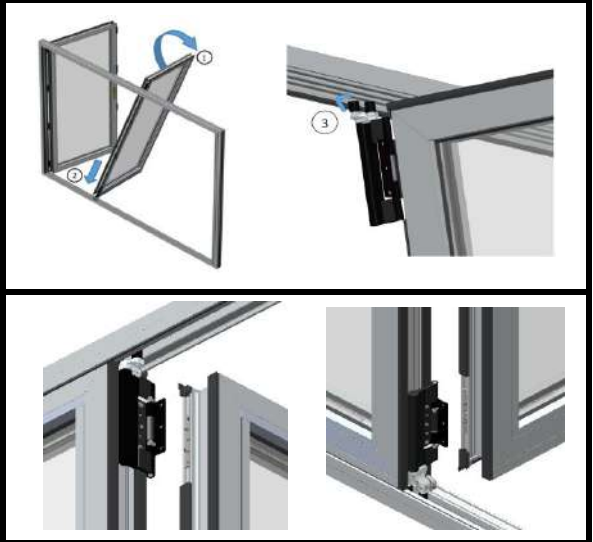

帶天地鎖門扇安裝

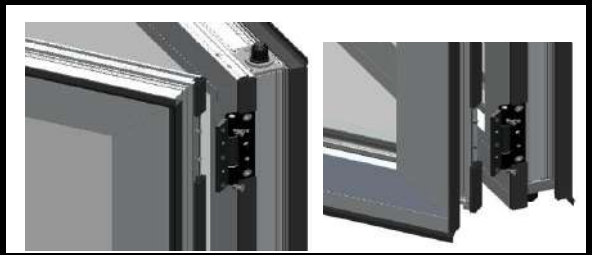

## 玻璃安裝

玻璃安裝步驟遵照英國BS 6262.準則操作

依” Toe & Heeled” 翹腳跟原理，'高低對角'，以墊片調整門扇，達到完美的垂直和水平  
支撐墊片防止玻璃移動並為門扇提供剛性，隔離玻璃與五金組件  
裝上鋁壓條，將EDPM密封膠條壓入鋁壓條與玻璃間，對玻璃緊實壓緊

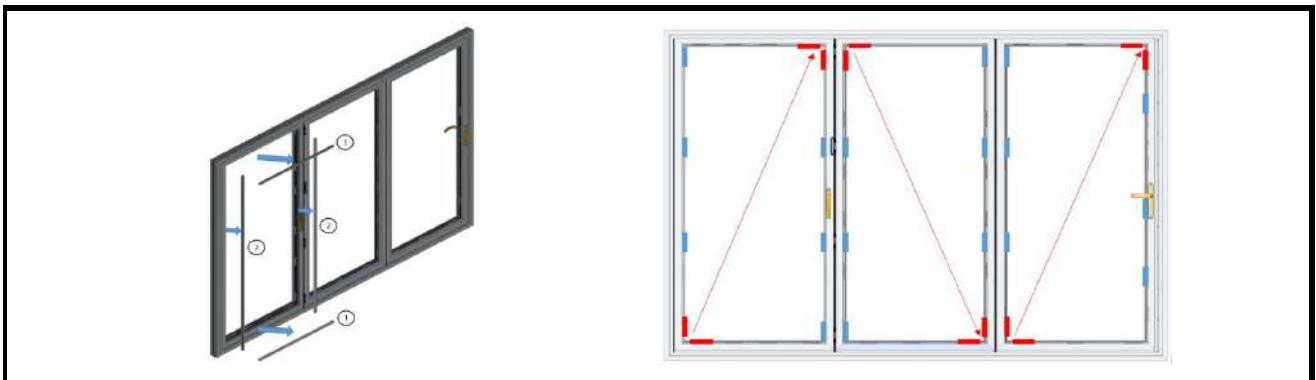

## 摺疊門扇檢查

確保面板框架之間的垂直間隙，密封膠條無傾斜，緊實壓迫

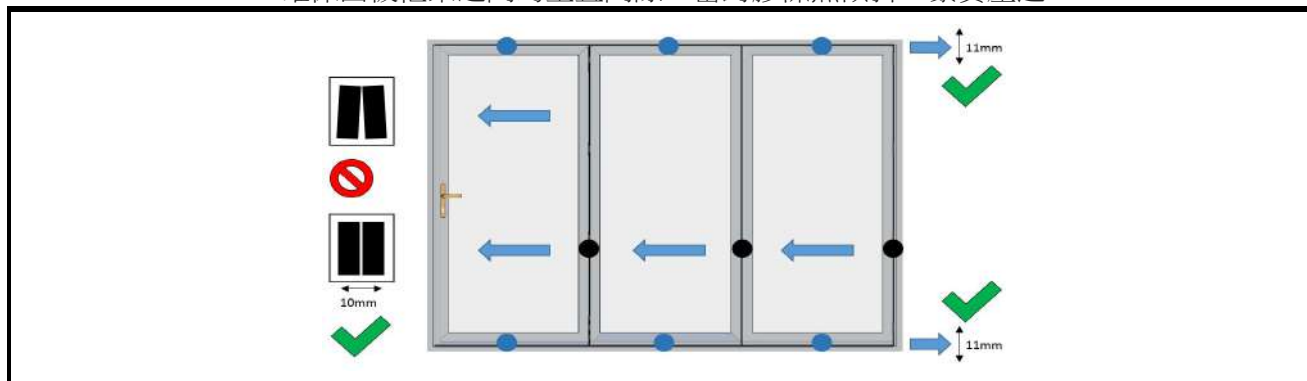

## 主門多點鎖的安裝與調整

安裝多點鎖具和全長型門扣板

調節可調節側柱，調節距離避免鎖和鎖扣有碰撞情形

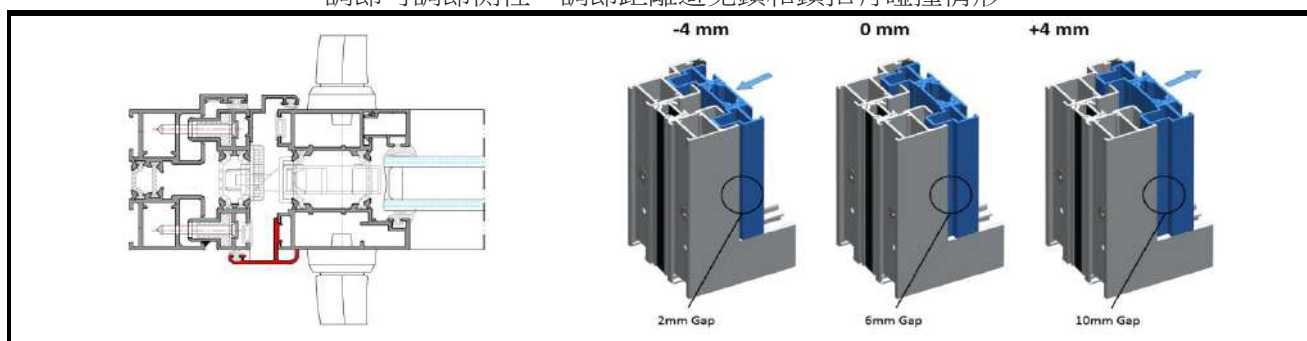

## 摺疊門組操作檢查

檢查摺疊門的基本運行操作，確保機構正常工作

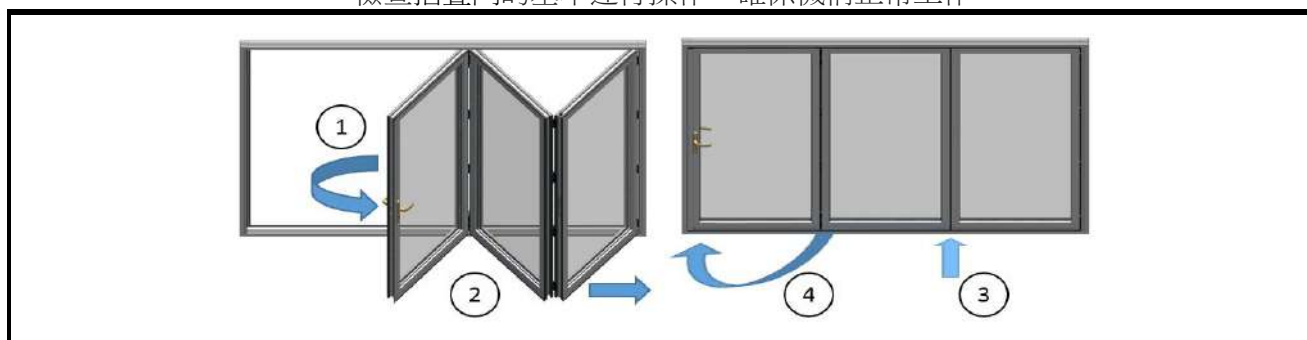

安裝完成